

SPECIFICATIONS	
INPUT VOLTS	12 VDC - 24 VDC
OUTPUT SPEED	1000/14000 RPM
OUTPUT HP	UP TO .25HP, CONTINUOUS
SHAFT DIA "ØD"	Ø .375 STD
SHAFT EXT. "S"	AS REQUIRED
SHAFT FEATURE	FLAT, KEYWAY, OR AS REQUIRED
MOUNTING	FACE MOUNT AS SHOWN
BRUSHES	INTERNAL OR EXTERNAL REPLACEABLE
LEAD WIRES	AS REQUIRED
BEARINGS	BALL BEARINGS
INSULATION	UL CLASS H
MOTOR TYPE	SERIES DM28
FAN COOLED	OPTIONAL

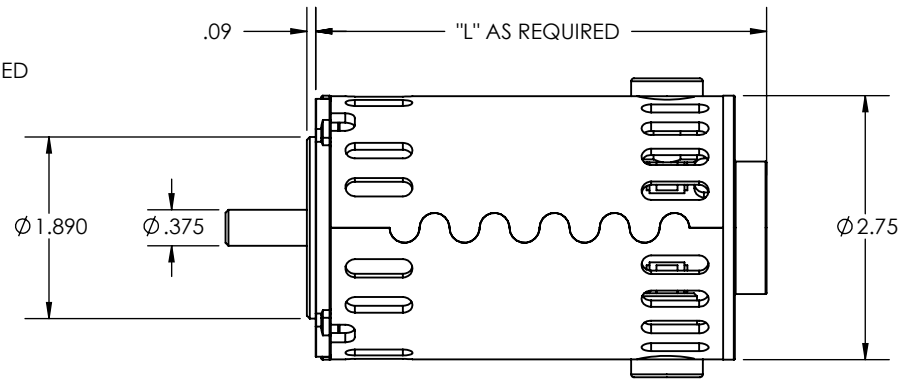
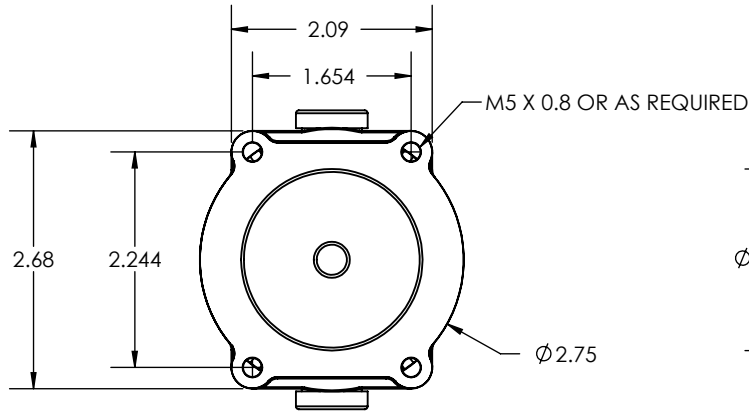

DESIGN APPROVAL	DATE	UNSPECIFIED TOLERANCES	REV.	DESCRIPTION	DATE	ECN
DES. ENG.	2/15/2013	.XXX ± .005 .XX ± .015 .X ± .050		This Drawing is the property of the Dumore Corporation. It must not be reproduced or copied without written permission.		
MFG. ENG.		MACHINE FINISH 125 ✓			PART NO.	
Q.C.		ANGLES ± 1°			DM28 VENTED	
SALES		CONCENTRICITY .005 TIR			DUMORE CORPORATION	
		SQUARENESS .001 PER IN.			1030 VETERANS ST. MAUSTON, WI 53948	
DO NOT SCALE DRAWING MUST BE RoHS COMPLIANT		REMOVE ALL BURRS BREAK SHARP CORNERS	TITLE		DM28, PMDC MOTOR	
MATERIAL SPEC.		Req. per Piece	RECEIVED AS	DWG. BY	DATE	SCALE
		Pattern No.	3-D AVAILABLE	CRD. BY	2/15/2013	1:2
					2/15/2013	