

PART NO.
DP150

SPECIFICATIONS	
INPUT VOLTS	12 VDC - 240 VDC
OUTPUT SPEED	1-1200 RPM.
OUTPUT TORQUE	UP TO 150 IN-LBS, CONTINUOUS
GEAR RATIO	5:1 - 1369:1
SHAFT DIA "ØD"	UP TO Ø.500 STD
SHAFT EXT. "S"	AS REQUIRED
SHAFT FEATURE	FLAT, KEYWAY, OR AS REQUIRED
MOUNTING	FACE, FOOT, OR AS REQUIRED
BRUSHES	INTERNAL BRUSH CARD, OR REPLACEABLE BRUSHES
LEAD WIRES	AS REQUIRED
BEARINGS	BALL BEARING, OUTPUT BEARING SUPPORT ON INPUT SHAFT
INSULATION	UL CLASS H
MOTOR TYPE	SERIES DM32

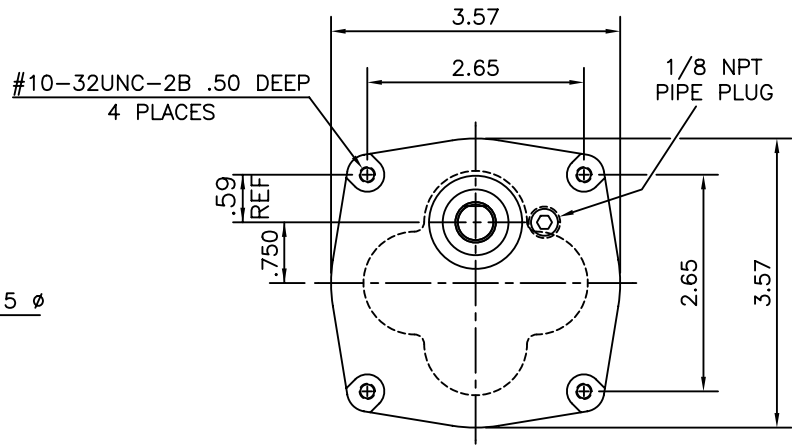
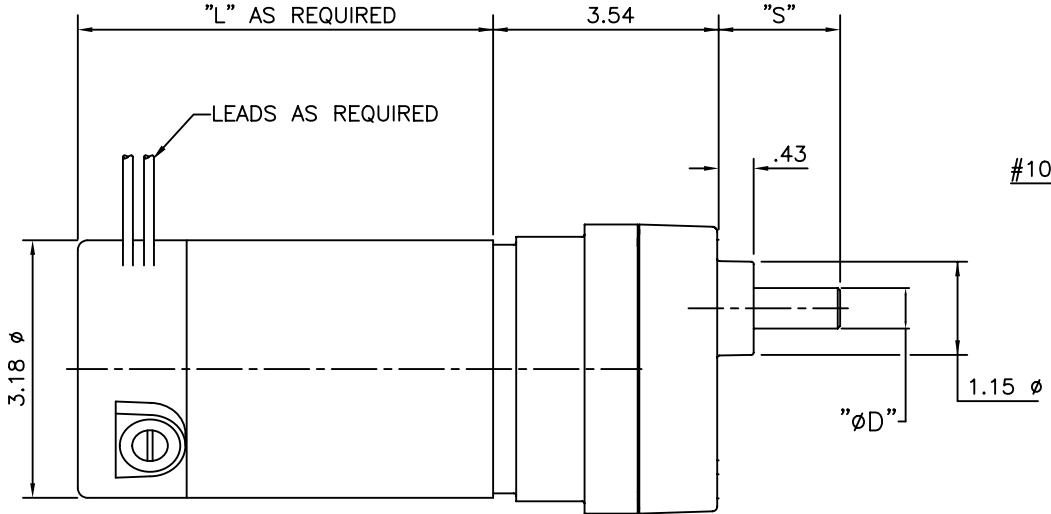

USE:

DESIGN APPROVAL	DATE	UNSPECIFIED TOLERANCES	This Drawing is the property of the Dumore Corporation. It must not be reproduced or copied without written permission. 1030 VETERAN ST. MAUSTON, WI 53948	PART NO. DP150
DES.ENG.		xxx ±.005		
MFG.ENG.		xx ±.015		
Q.C.		x ±.050		
SALES		Machine Finish	±.002 Max.	
		Angles	±1°	
		Concentricity	.005 TIR	
		Squareness	.001 per in.	
DO NOT SCALE DRAWING		REMOVE ALL BURRS BREAK SHARP CORNERS	TITLE	3.2" PARALLEL SHAFT GEARMOTOR
MATERIAL SPEC.			RECEIVED AS	DATE
			DATE	SCALE