

8 7 6 5 4 3 2 1

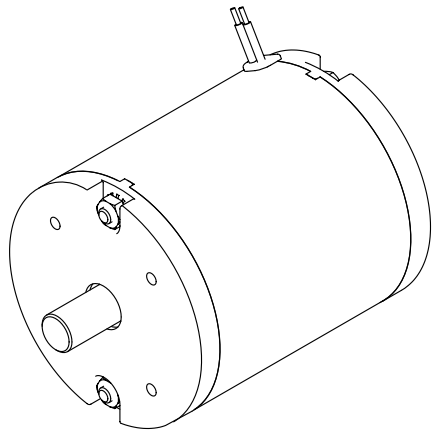

SPECIFICATIONS	
INPUT VOLTS	12 VDC - 240 VDC
OUTPUT SPEED	1000 TO 8000 RPM
OUTPUT H.P.	UP TO 1 H.P. CONTINUOUS
SHAFT DIA ϕ D'	ϕ .500 STD, OR AS REQUIRED UP TO ϕ .750
SHAFT EXT. 'S'	AS REQUIRED
SHAFT FEATURE	FLAT, KEYWAY, OR AS REQUIRED
MOUNTING	FACE MOUNT, FOOT MOUNT, OR AS REQUIRED
BRUSHES	INTERNAL BRUSH CARD, OR REPLACEABLE BRUSHES
LEAD WIRES	AS REQUIRED
BEARINGS	BALL BEARING
INSULATION	UL CLASS H

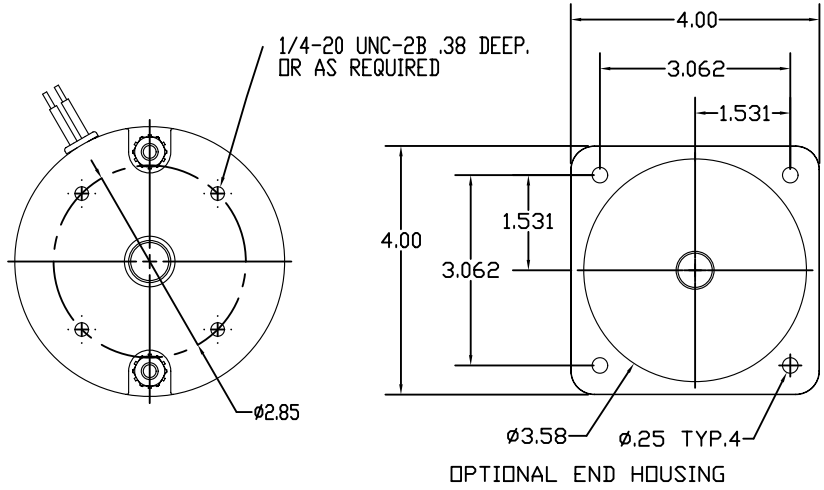
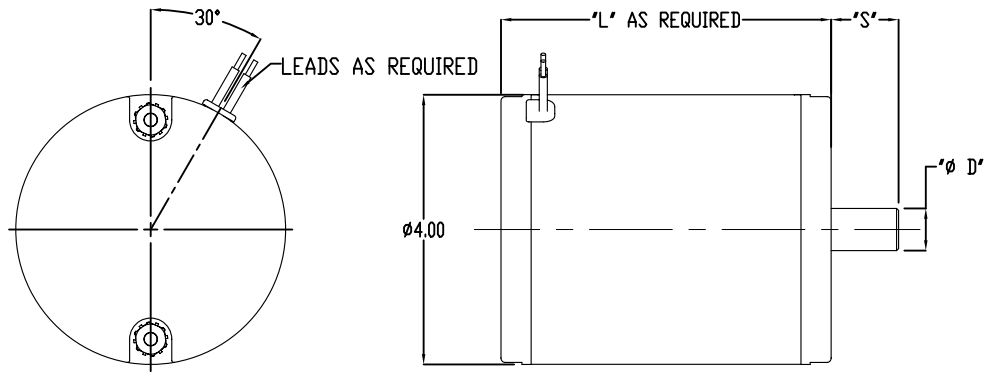

D
C
B
A

D
C
B
A

8 7 6

DESIGN APPROVAL	DATE	UNSPECIFIED TOLERANCES	This drawing is the property of the Dumore Corporation. It must not be reproduced or copied without written permission.	 PART NO. DM40 DUMORE CORPORATION 1030 VETERANS ST. MANASSAS, VA 20108
DWG. ENG.		± .015		
MFG. ENG.		± .010		
DLC		± .005		
SALES		± .002		
DO NOT SCALE DRAWING		REMOVE ALL BURRS BREAK SHARP CORNERS	TITLE	
MATERIAL SPEC.			4.0" PMDC MOTOR	SCALE