

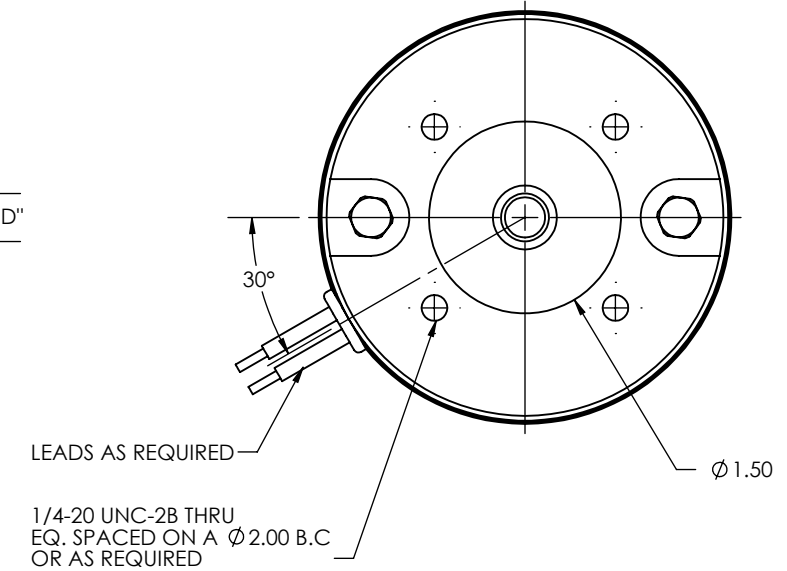

DM4400 PWM SINGLE QUADRANT MICROPROCESSOR DC MOTOR CONTROL			
12 VDC		120 VAC	
INPUT VOLTAGE	12 VDC	INPUT VOLTAGE	90-130VDC
MAX OUTPUT CURRENT	25A CONT.	MAX OUTPUT CURRENT	3A CONT.
PWM RATE	22 kHz, 0-100% DUTY CYCLE	PWM RATE	22 kHz, 0-100% DUTY CYCLE
CURRENT LIMITING	YES	CURRENT LIMITING	YES
MOTOR HP RATING	1/50 TO 3/8 HP @ 12VDC	MOTOR HP RATING	1/50 TO 1/4HP @ 115VAC 1Ph

MOTOR SPECIFICATIONS	
INPUT VOLTS	12 VDC - 120 VDC
OUTPUT SPEED	1000-6000 RPM
OUTPUT H.P.	UP TO .5 H.P. CONTINUOUS
SHAFT DIA " ϕ D"	ϕ .375 STD, OR AS REQUIRED UP TO ϕ .500
SHAFT EXT. "S"	AS REQUIRED
SHAFT FEATURE	FLAT, KEYWAY, OR AS REQUIRED
MOUNTING	FACE MOUNT, FOOT MOUNT, OR AS REQUIRED
BRUSHES	INTERNAL BRUSH CARD, OR REPLACEABLE BRUSHES
LEAD WIRES	AS REQUIRED
BEARINGS	BALL BEARING
INSULATION	UL CLASS H

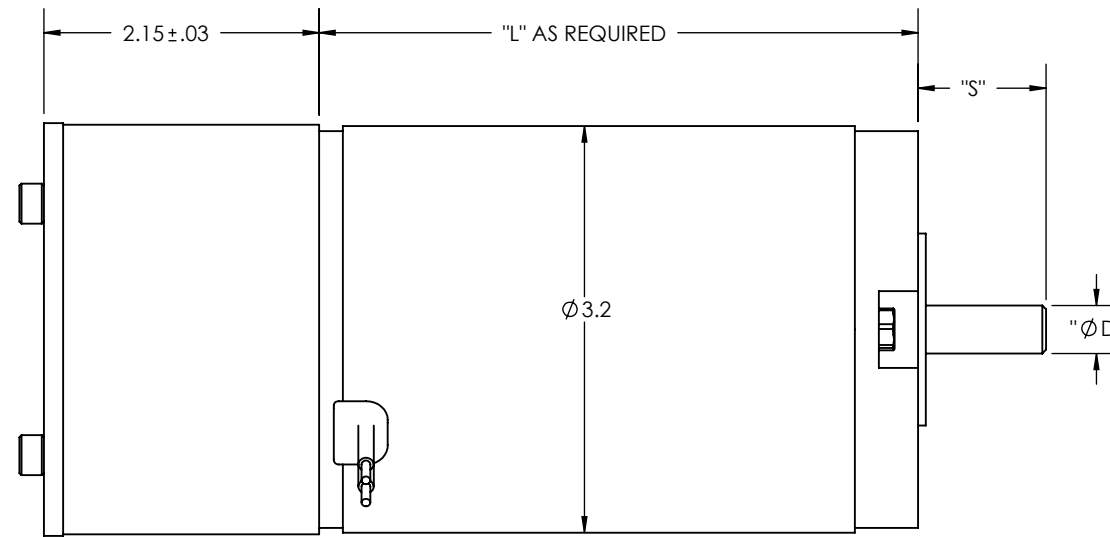
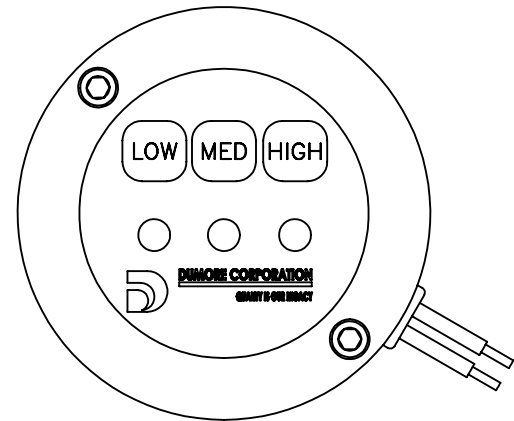

DESIGN APPROVAL	DATE	UNSPECIFIED TOLERANCES	This Drawing is the property of the Dumore Corporation. It must not be reproduced or copied without written per-mission.		PART NO.
DES. ENG.	3/15/2011	.xxx ± .005			DM4400
MFG. ENG.		.xx ± .015			DUMORE CORPORATION 1030 VETERANS ST. MAUSTON, WI 53948
Q.C.		x MACHINE FINISH			
SALES		ANGLES ± 1°			
		CONCENTRICITY .005 TIR			
		SQUARENESS .001 PER IN.	TITLE		
DO NOT SCALE DRAWING		REMOVE ALL BURRS BREAK SHARP CORNERS	MOTOR CONTROLLER		
MATERIAL SPEC.	Req. per Piece	RECEIVED AS	DWG. BY	DATE	SCALE
	Pattern No.	3-D AVAILABLE	CKD. BY	DATE	